



30 LITRE DIGITAL  
**Wi-Fi AIR FRYER  
TOASTER OVEN**

Cook different amazing food with one device



**543320**

When using electric appliances basic safety precaution should always be followed. Do not use BridgePro Wi-Fi Air Fryer Oven until you have read this manual thoroughly. Please keep this instruction manual in a safe place.

Visit BridgePro Online Store [www.bgepro.com/shop/](http://www.bgepro.com/shop/)  
Download our Recipe Cookbook at [www.bgepro.com/bridgepro-air-fryer-recipes/](http://www.bgepro.com/bridgepro-air-fryer-recipes/)



# TABLE OF CONTENTS

---

IMPORTANT SAFEGUARDS.....	3
GETTING TO KNOW YOUR WIFI AIR FRYER TOASTER OVEN .....	7
MAIN COMPONENTS .....	7
BEFORE FIRST USE .....	8
TEST RUN .....	10
FEATURES.....	10
TECHNICAL SPECIFICATION .....	10
USING THE CONTROLS & DISPLAY PANEL .....	11
OVEN FUNCTIONS.....	14
DUAL COOK FUNCTION: QUICK REFERENCE GUIDE .....	16
INSTRUCTIONS ROTATING EQUIPMENTS USE.....	17
ACTIVATING WIFI CONNECTIVITY .....	18
Watch the Instruction Video for Guidance.....	18
Set the appliance in WiFi connectivity mode .....	18
Download the APP.....	18
CARE & MAINTENANCE .....	23
WARM TIPS.....	25
GENERAL TIPS .....	26
REPLACING THE LIGHT.....	27
DISASSEMBLING THE INNER GLASS DOOR FOR CLEANING .....	27
STORAGE & TROUBLESHOOTING.....	29
WARRANTY .....	31
REGISTER WARRANTY.....	31
TERMS & CONDITIONS .....	32
NOTES.....	33

# IMPORTANT SAFEGUARDS

---

Always follow basic safety precautions when using your Air Fryer Toaster Oven.

## READ ALL INSTRUCTIONS BEFORE USE

- **Unplug** the appliance from electrical outlet when not in use and before cleaning. Allow the appliance to cool down before cleaning or handling, or putting on or taking off parts.
- **Do not** touch hot surfaces without using heat protective gloves. To avoid burns, use extreme caution when removing hot food, accessories or disposing of hot grease.
- When removing food or utensils from the cavity, the carrying tong provided should be used or insulated oven gloves worn to avoid burns from the heat.
- During operation, hot steam is exhausted through the rear exhaust port. Hands and face should be kept at a safe distance away from all exhaust vent. Care must be taken when near the appliance when in operation.
- Ensure that your power supply can carry no less than 13A.
- The appliance should be placed on a horizontal or stable tabletop when in use.
- **Do not** immerse the power cord, plug or any parts of the appliance in water or other liquids to prevent against electrical hazard or the shorting of electrical circuitry. Do not wash the appliance under the tap to avoid damage or danger.
- **Do not** cover the air inlets, outlets and sockets on the appliance during work.
- **Do not** operate any appliance with a damaged cord or plug. If the appliance is dropped or damaged, please replace the product.
- To avoid **potential injury**, do not use accessories or attachments not provided for the unit.
- **Do not** use outdoors or in remote unattended areas.

- **Do not** use or place on or near a hot gas or electric burner.
- **Do not** use this appliance for other than the intended use.
- To avoid **potential hazards**, do not put the product next to or use by children.
- **Do not** let the cord hang over the edge of a surface where the potential of children or pets' interaction is present.
- This appliance is not intended for use by persons (including children) with reduced physical, sensory, or mental capabilities, or lack of experience and knowledge, unless they are supervised or given instruction concerning use of the appliance by a person responsible for their safety.
- Children should be supervised to ensure that they do not play with the appliance.
- **Extreme caution** should be taken when using containers constructed of materials other than metal or glass in the appliance.
- **Do not** store any materials other than manufacturers recommended accessories in this appliance when not in use.
- **Do not** place any of the following materials in this appliance: cardboard, plastic, paper, or similar.
- **Do not** place oversized foods and utensils into this appliance as they may create a risk of fire, electrical shock, or shorting of electrical circuitry.
- **Do not** place on plastic, wooden boards or any other surface that is not heat and wear resistant.
- **Do not** use this appliance for any purpose other than as described in this manual.
- **A fire or shorting of electrical circuitry** may occur if the appliance is covered or touching flammable materials such as curtains, draperies, or walls when in operation.
- **Do not** plug in the power supply or operate the control panel with wet hands.

- **Do not** place anything on top of the appliance. No items should be placed on top of the appliance when in use or operation.
- **Warning:** To avoid possibility of fire, never leave the appliance unattended during use. Use recommended temperature settings for all function.
- **Do not** clean with metal scouring pads. Pieces can break off the pad and touch electrical parts, creating risk of electrical shock, or shorting of electrical circuitry.
- **Do not** clean with acidic cleaning substances and solutions. **ACIDIC SUBSTANCES** will disclosure the appliance internal surface and lead to corrosion and rust formation.

**The internal metal within the appliance is made from stainless steel. Stainless steel is naturally corrosion-resistant, but it is not immune to rust. Exposure to damaging chemicals like abrasive or acidic cleaning agents (e.g. containing any amount of hydrochloric or sulphuric acid, bleach, or chlorine, vinegar, and such liquids) will cause corrosion. Use of such cleaning agents invalidates your warranty.**

- **Do not** rest cooking utensils or baking dishes on the glass door. If the surface of the glass is scratched, this can cause the glass to break.
- **Do not** operate the appliance under a wall cabinet or remote areas such as a garage. When storing the appliance in remote areas, always unplug the unit from the electrical outlet.
- Ensure the appliance is placed at least approximately 10 cm from walls or on other apparatus. Do not operate inside a wall cabinet.
- Check if the voltage indicated on the appliance corresponds to the local main voltage before connecting the appliance.
- If the pre-set time is too long during a cooking operation, the food will burn and smoke may be released from the exhaust port. Immediately cut off the power and clean food waste and grease from the grease tray and other accessories.
- Always re-insert the crumb tray into the oven, beneath the heating elements.

- When the unit is not in use and before cleaning, press the power button off and remove the oven from the electrical outlet.
- Do not place the appliance near hot gas or electric burner.
- Do not cover the oven tray or rack with metal foil. This will cause overheating of the appliance.
- Oversize foods or metal utensils must not be inserted in the appliance as they may cause fire or risk electrical shock.
- **NEVER** leave the oven unattended while in use.

## **FOR HOUSEHOLD USE ONLY SAVE THESE INSTRUCTIONS**

### **NOTE**

- **You may smell a slight odor and smoke on first use. This is due to the production residue burning off the appliance and heating elements upon initial use. This is completely normal and will fade away with use.**
- The manufacturer or retailer is not responsible for any problems arising from incorrect use by the customer.
- **Do not** unplug the appliance immediately after cooking to avoid damage to the appliance due to increased residual temperature inside the appliance.
- After cooking and the appliance has cooled down, unplug it from the mains, clean the oven cavity, clean the waste in the drip tray and place it in a ventilated, dry and non-corrosive environment.
- This oven uses a short power supply cord to reduce the risk of entangling or tripping. Use extension cords with care. The marked electrical rating of the extension cord must be as great as the rating of the oven.
- Place crumb tray below lower heating elements. **DO NOT** slide crumb tray into any other rack positions.

# GETTING TO KNOW YOUR WIFI AIR FRYER TOASTER OVEN

## MAIN COMPONENTS

Main Unit (with attached power cord)

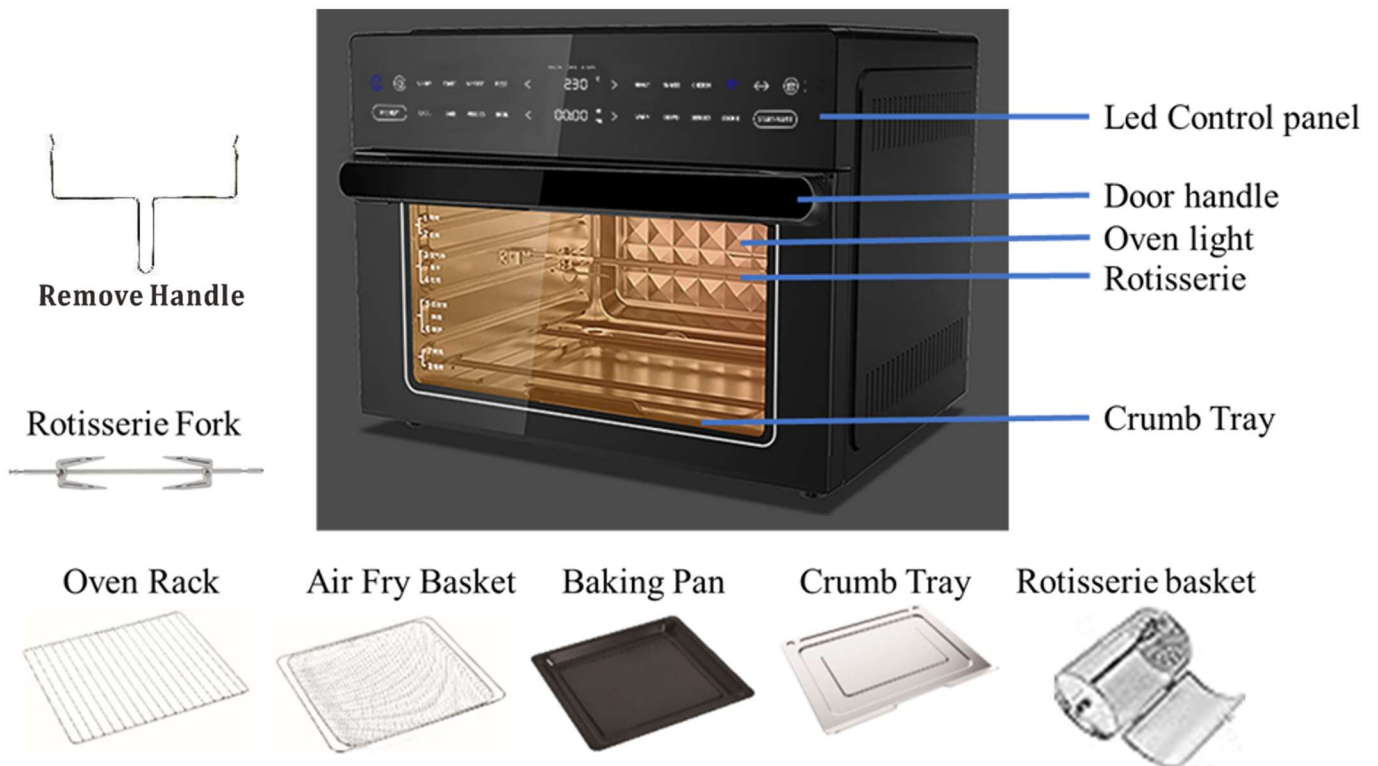

Place crumb tray below lower heating elements. DO NOT slide crumb tray into any other rack positions.

<b>Air fryer basket</b>	Use for fries, chicken wings, onions, etc. It can also be used as a dehydrate basket. Use with air fry cooking mode.
<b>Oven rack</b>	Use for meat, bread, pizza, etc. Use on its own or place on top of the baking pan.
<b>Baking pan</b>	Contains a non-stick coating that is PFOA free, and food grade compliant PTFE. Use on its own or place under air fryer basket to collect drips from food.
<b>Rotisserie Fork</b>	Use for rotisserie chicken, turkey, and meat.
<b>Carry tong / handle</b>	Use to remove rotisserie accessories from the oven.

<b>Crumb tray</b>	Use to catch and remove crumbs of food falling during the cooking process. Place below lower heating elements.
<b>Rotisserie basket</b>	Use for granular foods such as beans and nuts.

**Buy accessories from BridgePro Online Shop:**

[www.bgepro.com/product-tag/301-air-fryer/](http://www.bgepro.com/product-tag/301-air-fryer/)

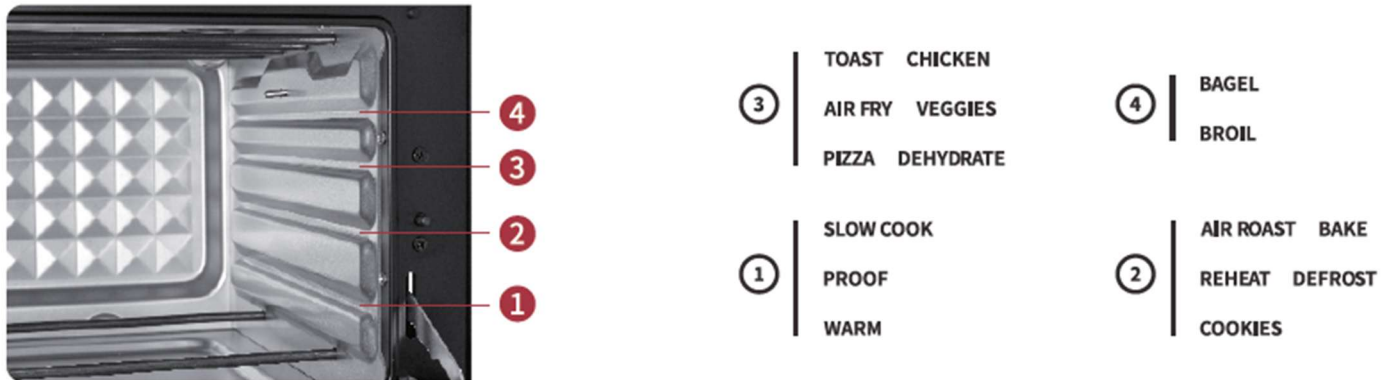

The oven has 4 rack levels, where your accessories can slide into the oven (see image above). When you select a function, refer to the corresponding rack as set out on the door glass to install accordingly.

**BEFORE FIRST USE**

1. Read the instructions included in this manual.
2. Remove all packaging materials carefully and choose a flat area to place the appliance. Ensure all accessories are removed from the packaging before disposing packaging materials.
3. Clean all accessories with warm water, dishwashing liquid, and soft lint.
4. Wipe the inside and outside of the appliance with a damp cloth.
5. On first use you may smell a slight odor and smoke fumes. This is due to the production residue burning off the appliance and heating elements upon initial use. This is completely normal and will fade away with use.

- 1** Remove all packaging around and inside the oven.

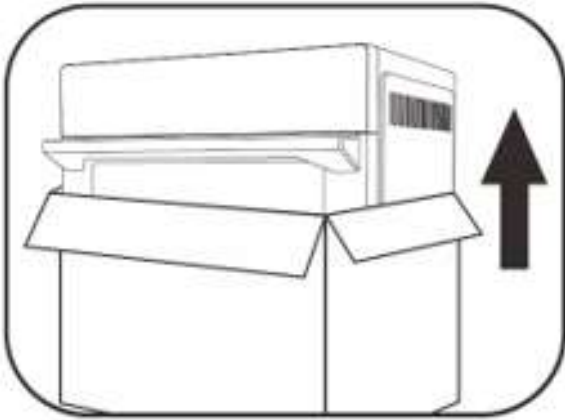

- 2** Place on a stable, level, heat-resistant surface, away from anything that can be damaged by heat. Keep at least 110mm distance between the electrical outlet and the wall, furniture, etc.

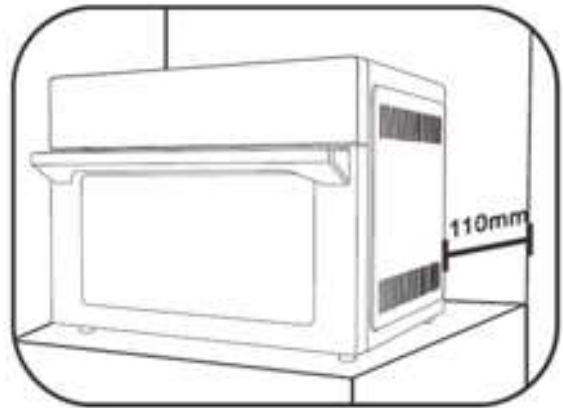

- 3** Remove the protective film from the control panel. This film is to protect the panel; you can tear it off or keep it on.

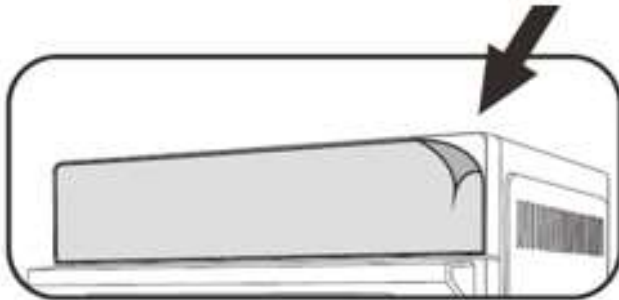

- 4** Wash all accessories and clean the interior of the Air Fryer Toaster Oven. Dry and place accessories back in the oven.

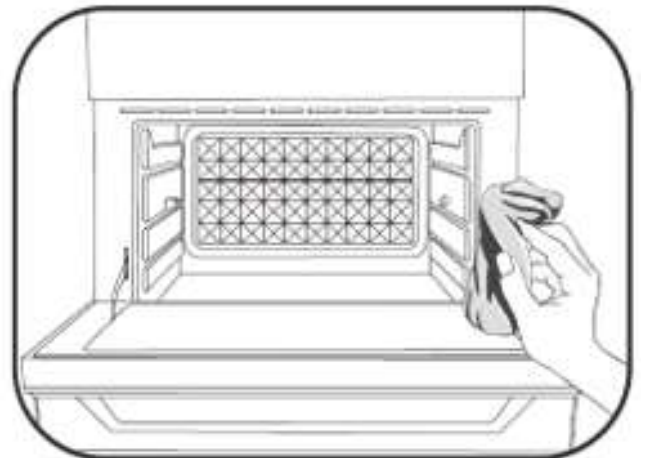

- 5** Before use, ensure that the power and outlet meet the requirements to operate this product (input power requirements).

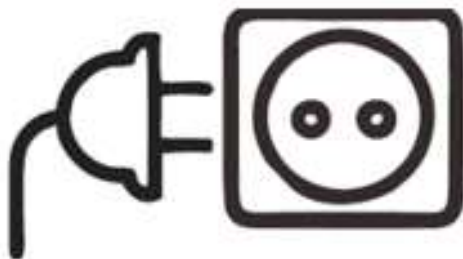

- 6** Upon first use, it is necessary to run the oven for 18 minutes at the highest temperature (230°C) to sterilize and remove any manufacturing odor. The appliance may even emit an odor or smoke due to the heaters protective film burning off.

## TEST RUN

A test run will help you be familiar with your oven; make sure it is working correctly and clean it of possible residues.

1. Make sure there is no food or packaging in the oven and plug it in.
2. Select AIR ROAST and set the temperature to 230°C for 18 minutes.
3. Press  to begin heating. The display will show the Air Roast light while other cooking modes are inviable. The timer will count down.
4. Upon count down the oven will beep several times and the roasting operation will stop.

### NOTE:

The oven may product some white smoke or steam during the test run. This is normal.

### CAUTION:

To avoid risk of injury or burns do not touch hot surfaces when the oven is in use. Take extreme care when removing accessories or any hot container from a hot oven. Always use oven gloves.

## FEATURES

**By using the all-new 360°C HOT AIR CIRCULATION technology, this appliance delivers delicious and healthy cooking result.**

### DOOR SENSOR

If the door is opened during a cooking operation, the operation will pause and the light will turn on. When the door is closed, the light will turn off and resume cooking. Make sure to keep the oven door closed during the cooking operation.

## TECHNICAL SPECIFICATION

Voltage	Power	Frequency	Capacity
220V-240V	1800W	50Hz	30L

# USING THE CONTROLS & DISPLAY PANEL

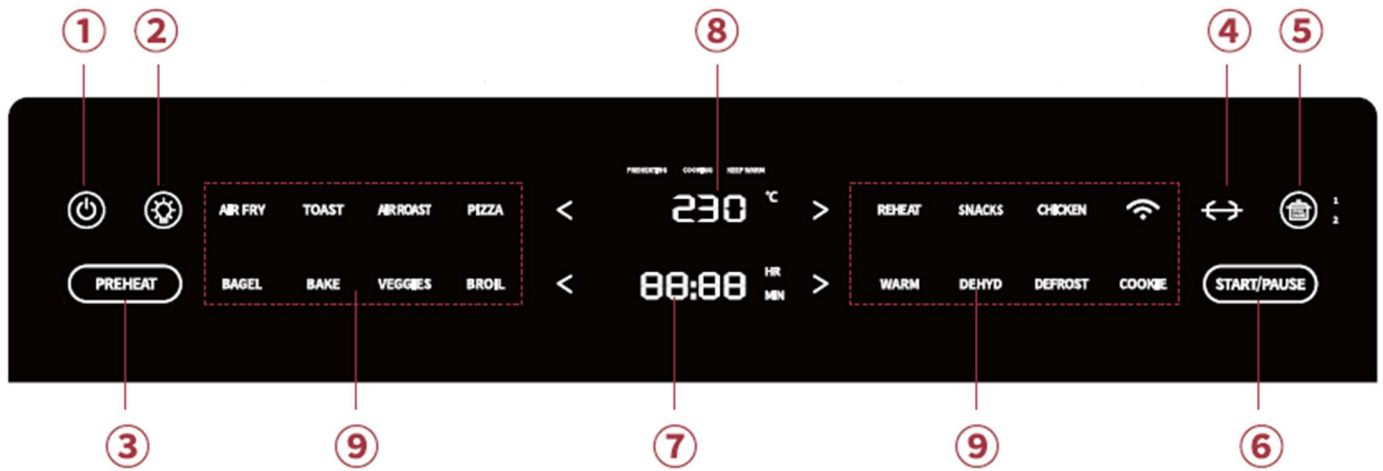

## 1. Power Buton

Press to turn oven on / off. While the oven is cooking, press to cancel cooking, the oven will return to standby. While the oven is in standby mode, press to turn off the oven.

## 2. Light Buton

Press to turn the interior light on/off.

## 3. Preheat Buton

Press to start preheating. Oven will beep once preheat mode is complete, and the display will show END.

## 4. Rotisserie

It is used to cook the food types that can be rotated. After selecting Rotisserie and setting the time/temp, touch the start icon to start cooking and then press the rotisserie button.

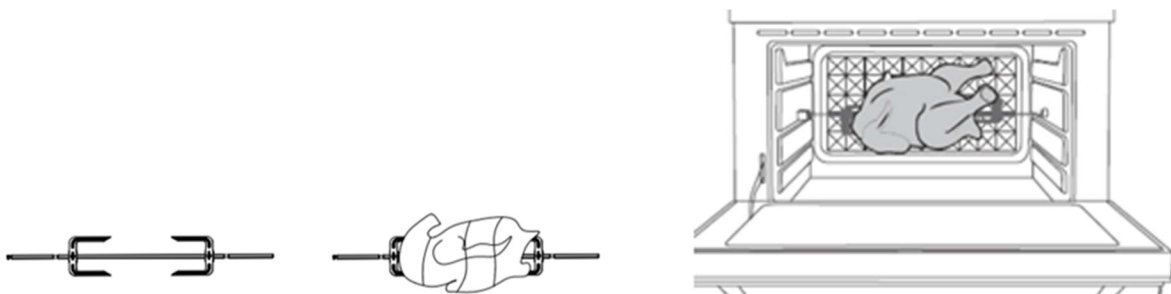







## 5. **Dual Cook Button**

Advanced dual function cooking technology allows you to program your appliance to start cooking with one preset, then automatically transition to a second preset for a perfect cook on any meal. For example, put a breadcrumb-topped casserole in the oven, set it to bake then broil, and it will cook through with a golden crisp topping to finish. Just set it and forget it. Enjoy your favorite fried food without any extra operations.



The functions that may be programmed using Dual Cook are bake, Broil, Air Roast, Pizza, Warm and Air Fry.

The steps of operation are as follows:

- i. Press  button, the functions related to dual cook light up.
- ii. Select the function to be activated, then press  button again to confirm.
- iii. Optional: Press TEMP and TIME  to set the temperature and time required for the function selected in step 2.
- iv. Repeat step 2 and 3 to select the second function to be activated for the dual cook.
- v. Place food to be cooked in the oven.
- vi. Press  button to start the cook. The oven will beep at the end of the set cook time.

## 6. **Start / Pause Button**

- Start or pause a cooking function.
- Press  to start a cooking operation, the time will count down once the cook function has started.

- Press  to pause a cooking operation, the cooking functions will flash.
- Press  during the cooking operation to change the cook function.
- Oven will beep several times after a cooking operation is finished, and the TIME display will show “End”.

**Note:**

When you open the oven door during a cooking operation, the oven will pause cooking automatically, and the interior light will turn on. When you close the oven door, the oven will resume cooking and the interior light will turn off.

If the cooking operation is paused for more than 15 minutes, the air fryer will stop cooking and return to standby mode.

7.  **Time Display and Adjustment Buttons**

Time display and adjustment button shows the cook time.

Press the arrows to adjust cooking time directly. Time will typically adjust in increments of ±1 minutes. Adjust by increments of 30 minutes for Dehydrate function.

8.  **Temperature Display and Adjustment Buttons**

Temperature display and adjustment button shows the cook temperature.

Press the arrows to adjust cooking temperature directly. Temperature will typically adjust in increments of ±1 °C.

**9. Cooking Functions**

Once you select a function, the temperature and time will set automatically in accordance with pre-programmed setting. You can change the programmed time and temperature at any time.

# OVEN FUNCTIONS



Name	Use	Accessory & Rack Level	Time & Temp Range
Air fry	Good for baking French fries and snacks	Air fryer basket at rack level 2	90 - 230 °C 1 min – 2 hrs
Toast	Toast slice of bread	Any	1 - 7°C 1 ~ 7 mins
Air roast	Good for baking egg tarts and waffles	Oven rack level 2	90 - 230 °C 1 min – 2 hrs
Pizza	Good for baking pizza and crispy cheese sticks	Baking pan or oven rack at rack level 2 or 3	90 - 230 °C 1 min – 2 hrs
Reheat	Heat leftovers without over cooking	Baking pan at rack level 2	90 - 230 °C 1 min – 2 hrs
Snacks	Produce various baked snacks that are crispy on the outside and soft on the inside, or crispy and delicious	Baking pan or oven rack at rack level 2 or 3	90 - 230 °C 1 min – 2 hrs
Chicken	Good for chicken wings, drum sticks, without oil	Air fryer basket at rack level 2 or 3	90 - 230 °C 1 min – 2 hrs
Bagel	Can make the outer layer of bread crispy, while the internal tissue is soft and chewy	Oven rack level 2	90 - 230 °C 1 min – 2 hrs

When cooking greasy foods like (e.g. chicken wings) insert the baking pan underneath the air fryer basket (on e.g. level 1) to catch oil drippings.

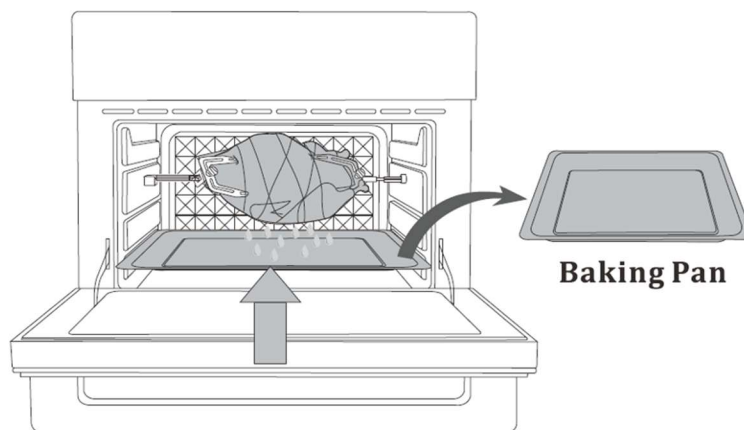

Name	Use	Accessory & Rack Level	Time & Temp Range
Bake	Good for baking cakes, muffins, and pastries.	Baking pan at rack level 2	90 - 230 °C 1 min – 2 hrs
Veggies	Evenly baked veggies.	Baking pan at rack level 3	90 - 230 °C 1 min – 2 hrs
Broil	Evenly broil meats, fish, and brown the tops of cooked food.	Baking pan at rack level 4	90 - 230 °C 1 min – 2 hrs
Warm	Keep food warm at the recommended temperature to prevent bacteria growth (70 °C or above).	Baking pan or oven rack at level 1	30 - 120 °C Up to 2 hrs
Dehydrate	Dehydrate combines low and stable heat with airflow to evenly dry out foods without cooking. Dehydrate meats, fruits, and vegetables for healthy snacks.	Oven rack or air fry basket at any rack level	30 - 80 °C Up to 24 hrs
Defrost	Thaw frozen food for cooking.	Baking pan at rack level 2	30 - 80 °C 1 min – 1 hr
Cookie	Bake cookies and other baked treats.	Baking pan or oven rack at rack level 2	90 - 230 °C 1 min – 2 hrs

\*Use the Time Range to control Toast function. For a golden-brown toast, consider default time 4 or 5 selection.

The above default data are for reference only. Upon function selection, the user can adjust the cooking operation temperature and time as desired to match the desired cooking result.

**Note: This air fryer oven technology enables faster cooking. Always monitor food to prevent over cooking. Adjust cooking time and temperature according to the portion size and your**

**Caution: The outer surface of the oven, including the oven door is hot during and after cooking operation. Always use protective equipment or oven gloves when inserting, removing, or handling items from the oven.**

## DUAL COOK FUNCTION: QUICK REFERENCE GUIDE

Function 1	Function 2	Preheat	Suggested Amount of Food	Suggested Accessory	Suggested Rack Position
Air Fry	Warm	Yes	Based on the food you select	Air Fryer Bkt	2
Bake	Broil	Yes		Baking Pan or Oven Rack	3
Air Fry	Warm	Yes		Baking Pan or Rotisserie Fork	4 or Rotisserie Fork Position
Air Roast	Air Fry	Yes		Baking Pan or Rotisserie Fork	
Air Fry	Broil	Yes		Air Fryer Bkt or Oven Rack	2 or 3

It is normal occurrence that some moisture may occur on the oven door during the cooking process. Consider pre-heating the appliance before cooking.

# INSTRUCTIONS ROTATING EQUIPMENTS USE

1. The use of the rotisserie rotating skewer accessory (OPTIONAL SPARE, NOT INCLUDED, PART NUMBER 543306-1) is as shown in the following section.

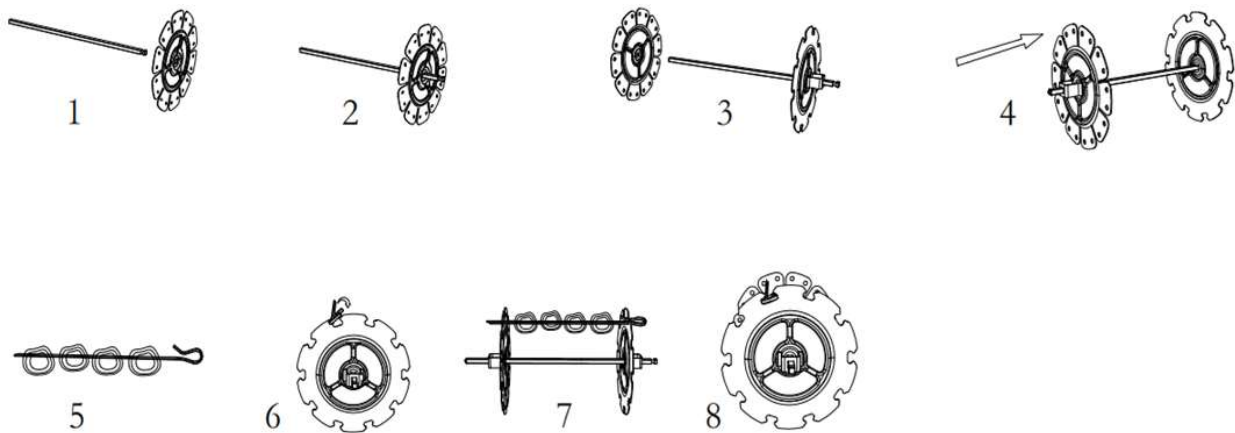

**Buy accessories from BridgePro Online Shop:**

[www.bgepro.com/product-tag/30l-air-fryer/](http://www.bgepro.com/product-tag/30l-air-fryer/)

2. The use of the rotisserie rotating drum accessory is as shown in the following section.

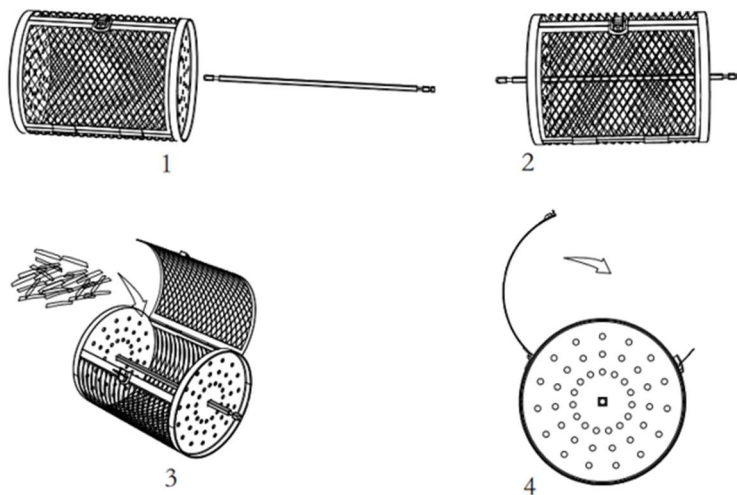

# ACTIVATING WIFI CONNECTIVITY

---

## Watch the Instruction Video for Guidance

1. <https://bgepro.com/product/bridgepro-wifi-30l-digital-air-fryer-oven-with-full-accessory-set/>

## Set the appliance in WiFi connectivity mode

1. After downloading the APP, Press the WiFi connectivity button on th control panel



## Download the APP

1. Please download the TUYA APP on your mobile phone store or APP STORE on the mobile platform, or scan the following QR code on your mobile phone.



TUYA APP QR code

2. Click on the TUYA APP to open the software. Register your account.

3. Click the “+” sign in the upper right corner to add a device, or directly click the “Add Device” button in the middle of the page.

4. Enter the “Add Manually/Auto Scan”, to select the corresponding product definition attribute. This product is an oven, and the kitchen appliance should be selected.

Alternatively select automatic search (make sure the device is powered on and the WIFI indicator is flashing), enter the next prompt interface, click the confirm button.

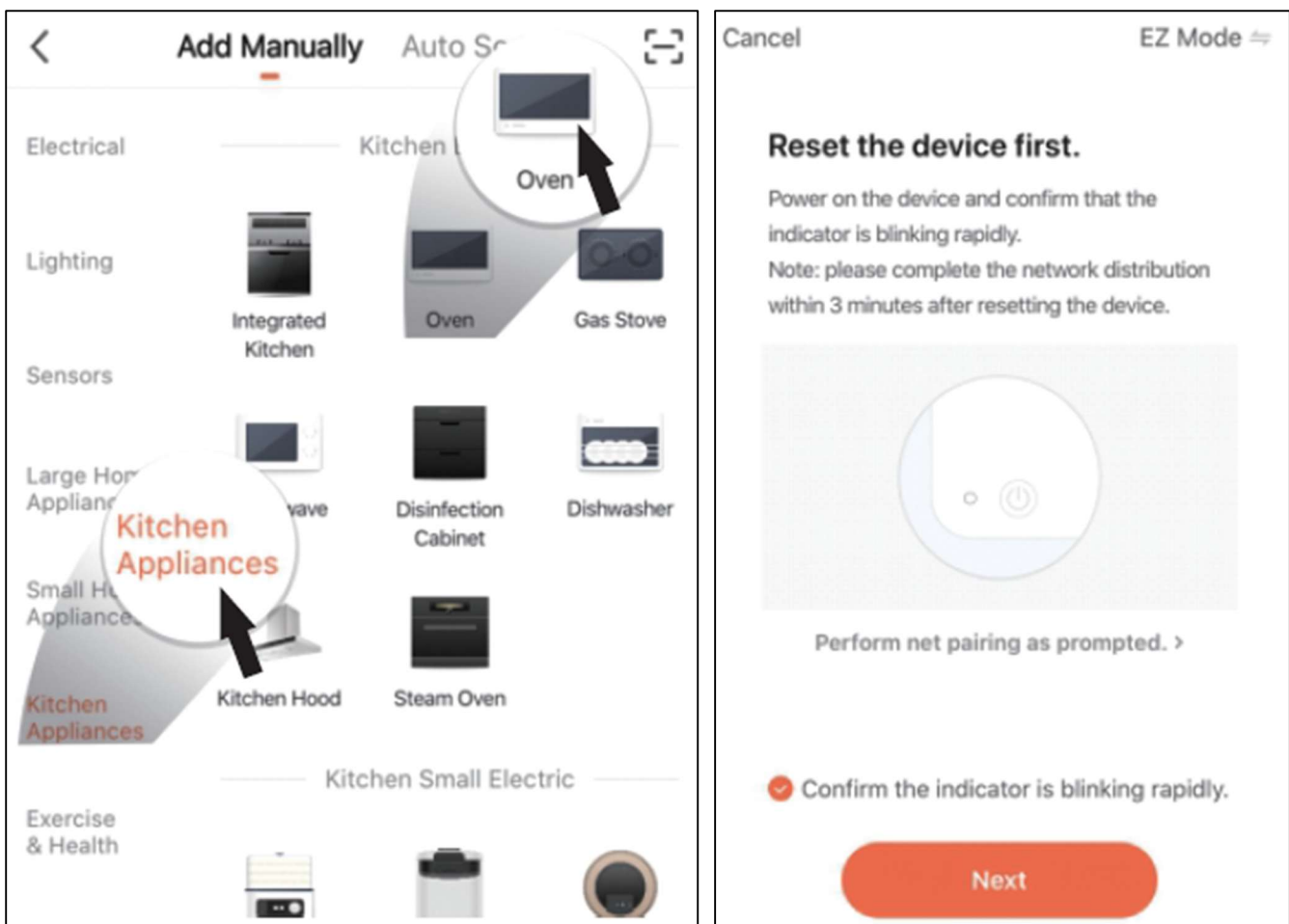

5. Enter the network to be connected to the device to add the device. The device only supports 2.4 Hz WIFI network. After entering the network password, you will enter a search device interface.

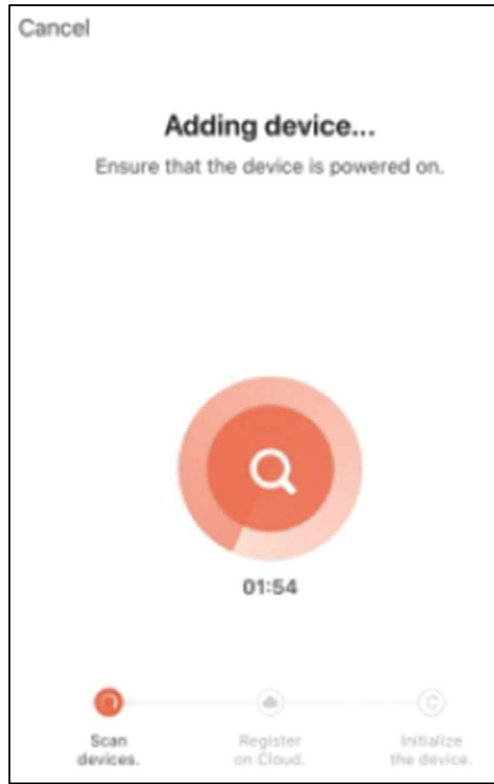
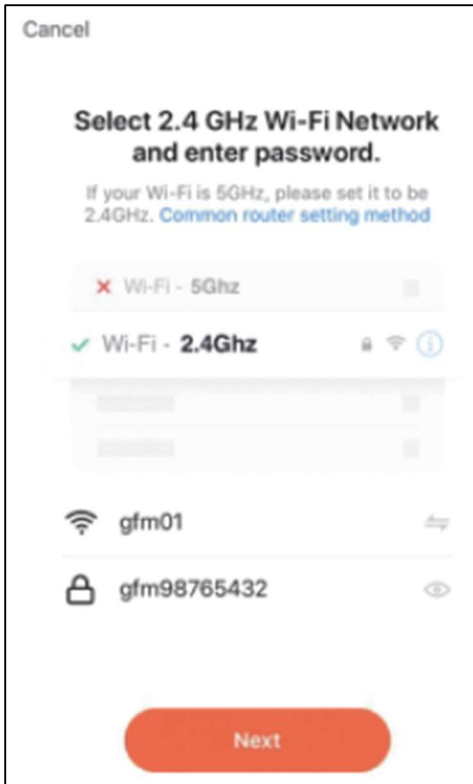

6. Search for devices that can be added and connect automatically.

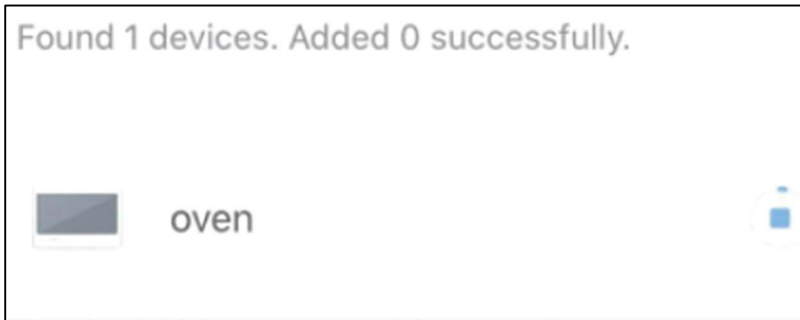

7. After the device is connected, it will enter the device use interface.

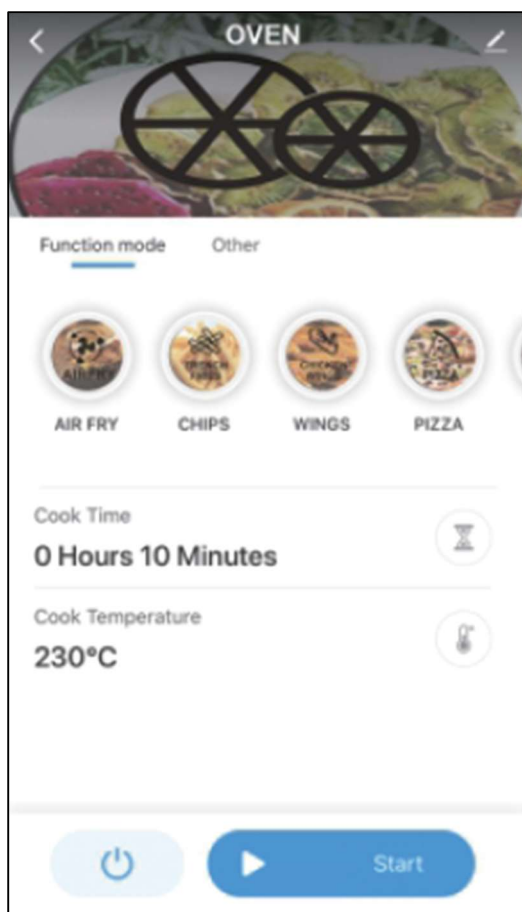

**8. Oven Power on/off:** Press the button in the app to turn the oven on. Pressing the same icon again will turn the oven off.

**9. Function selection menu:** Click the button that matches the function of interest to start the cooking operation.



**10. Time / Temperature:** Click the time / temperature adjustment icons, scroll the time and temperature values, and adjust as necessary for the cooking operations.

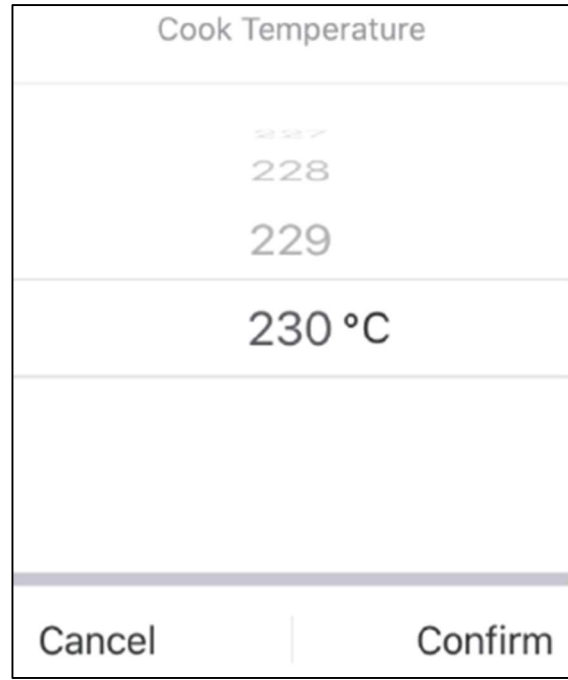
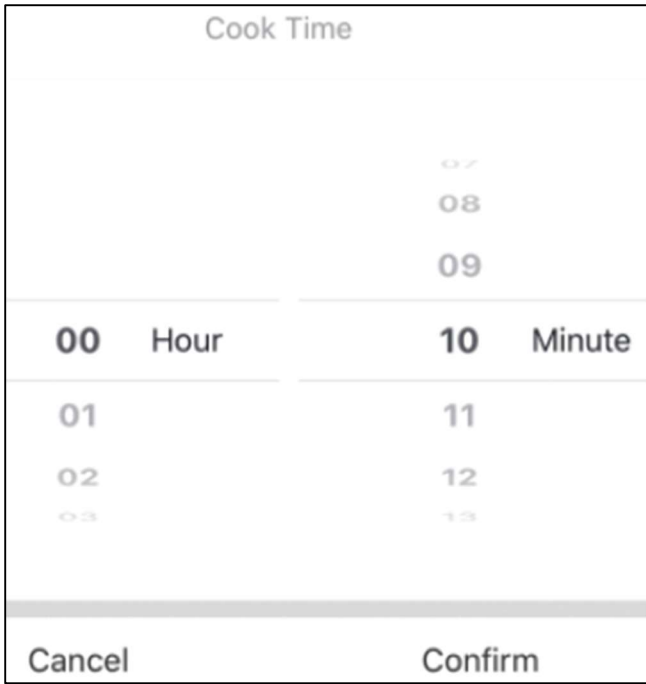

**11. Program Start/Pause:** Press the  button once to start the cooking operation, and press a second time to pause the cooking operation.

**12. Light  and Rotisserie ** : Select light On/Off button, select rotisserie On/off button.

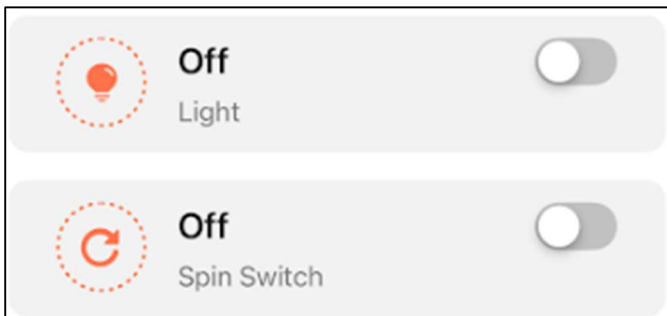

# CARE & MAINTENANCE

---

- This oven contains no user-serviceable parts. Any repairs should be performed by an authorized service representative.
- Clean the oven accessories (including the trays, etc.) and oven interior after every use.
- Do not use abrasive cleaners, metal scouring pads, or metal utensils on any part of the oven, including trays and other accessories. These will scratch or damage the surfaces.

## CLEANING THE OVEN

- Before cleaning, turn off and unplug the oven, and allow it to cool completely. Open the door for faster cooling.
- Empty the crumb tray by sliding it out of the oven.
- Apply non-abrasive liquid cleanser or a mild spray solution to a soft, damp cloth or sponge (not on the oven surface) and wipe all parts of the oven. Do not use a dry cloth on the display screen, or it may be scratched.
- To clean the glass door, use a glass cleanser or mild detergent and a soft, damp sponge or soft, plastic scouring pad.
- Let all surfaces dry completely before plugging in the power cord or turning on the oven.



## CLEANING THE ACCESSORIES

Note: After each use, slide out the crumb tray and discard crumbs.

- Apply non-abrasive liquid cleanser or a mild spray solution to a soft, damp

sponge or soft, plastic scouring pad (not the surface of the accessories). Wipe accessories and soak in warm soapy water if necessary.

- For stubborn grease on the accessories ONLY:
  - In a small bowl, mix 1.5 tablespoon / 30 ml of baking soda with 1 tablespoon / 15 ml of water to form a spreadable paste.
  - Use a sponge to spread the paste on the trays and gentle scrub. Let the trays sit for 15 minutes before rinsing.
  - Wash trays with mild soap and water.
- Dry thoroughly.
- Replace the crumb tray into the oven before plugging in the power cord or turning on the oven.



**The internal metal within the appliance is made from stainless steel. Stainless steel is naturally corrosion-resistant, but it is not immune to rust. Exposure to damaging chemicals like abrasive or acidic cleaning agents (e.g. containing any amount of hydrochloric or sulphuric acid, bleach, or chlorine, vinegar, and such liquids) will cause corrosion. Use of such cleaning agents invalidates your warranty.**



- Do not use hard cleaning tools.
- Do not use string cleaners
- This will damage the surface of the appliance and cause corrosion and rust.



## WARM TIPS

**1: Note:** After cooking oily food (e.g. chicken wings), there will be oil stains on the back plate and side plate of the oven, please clean it in time to avoid excessive accumulation of oil stains and leakage to the bottom of the appliance.

If oil stains are not cleaned in time, they will not come off.

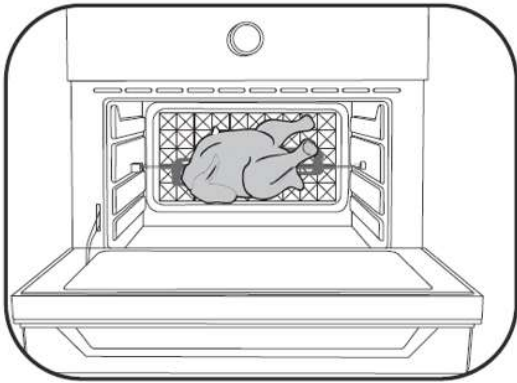

**3. Note:** If the chicken weighs less than 2.0kg, it is possible to use a rotisserie fork for roasting. By roasting with 360° rotation, the roasted chicken can be heated more evenly, avoiding the situation where parts of the chicken are burnt while other parts are uncooked. This way the chicken is roasted to a golden color and a better taste.

### Within 2.0kg: Use rotisserie fork

Consider using a cooking string to hold the chicken together during the roast cooking operation.

When using a cooking string to hold the chicken together, be careful not to tie tightly, best to loosely hold the meat together with the tied string, so hot air can still circulate around the chicken for optimal cooking result.

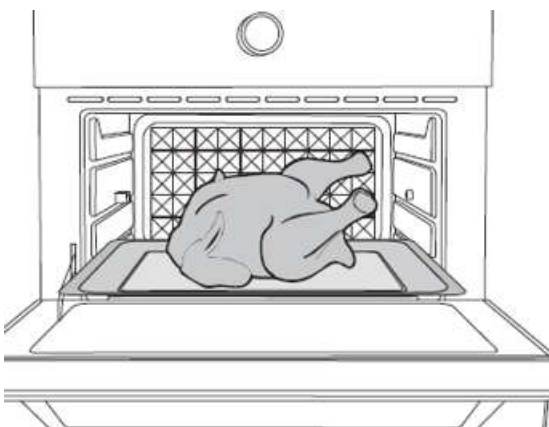

**4. Note:** If the chicken weighs between 2.0kg and 5.4kg, it is recommended to use a baking pan on the bottom shelf of the oven for roasting. A large capacity roasted chicken needs more space to ensure even heat. Placing the chicken on the bottom shelf ensure adequate heat transfer from the heating elements to all parts of the roasting chicken.

# GENERAL TIPS

**1: Note:** The upper heating elements will NOT turn orange / red during cooking operations – this is normal. The wattage of the top heating elements differs from the bottom heating elements to maintain an appropriate oven chamber temperature.

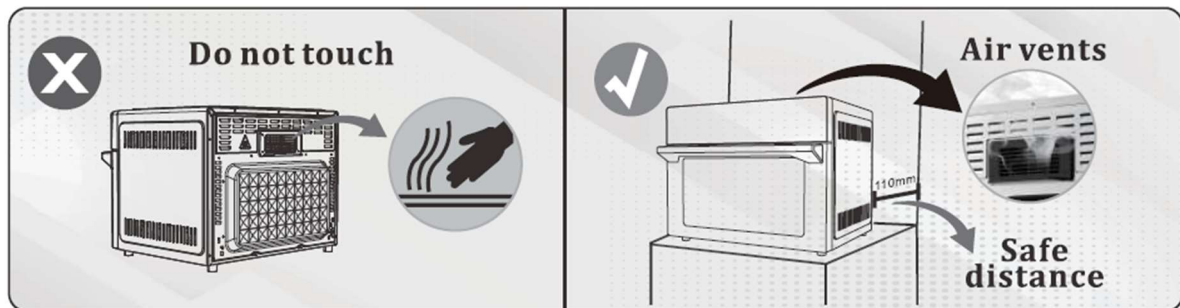
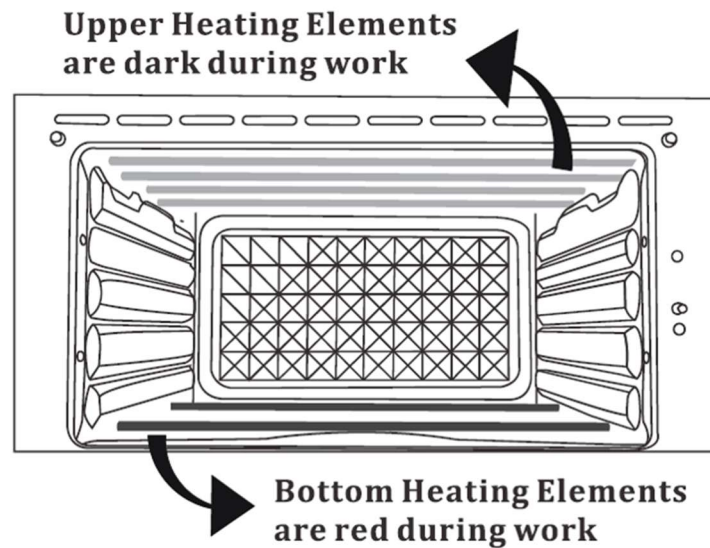

## CAUTION:

- Hot air and smoke may be emitted from the back of the appliance through the cooking process. This is normal as the specially designed vent helps to remove excess moisture from crispy results.
- Do not position the vent towards any area that can be directly touched by humans to prevent burns.
- Please ensure a minimum distance of 110mm between the appliance and the wall when placed on a counter top.

- The appliance is designed for baking high temperature products. When operating the appliance, take caution to avoid placing it near curtains and other flammable objects.

## REPLACING THE LIGHT

**Attention:** Be sure to unplug the appliance and allow it to cool completely before replacing the oven light.

**Specification:** 25W Halogen Bulb

1. Rotate the light cover clockwise to remove it.

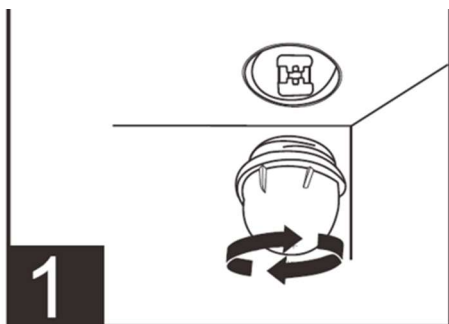

2. Remove the used bulb by pulling it directly.

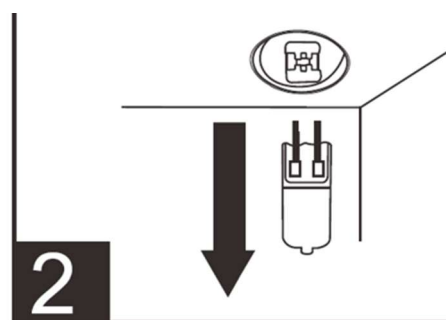

3. Insert the new bulb

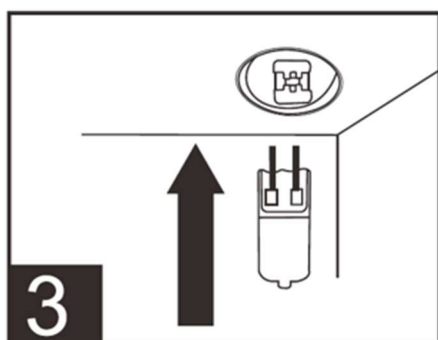

4. Rotate the light cover anti-clockwise to tighten it.



## DISASSEMBLING THE INNER GLASS DOOR FOR CLEANING

**Attention:** Be sure to cool down the glass door completely before disassembly.

1. Turn the screw anti-clockwise using a screwdriver.
2. Use the silicone suction cup to lift up the glass, and then take out the glass

from its housing using your hands.

3. After cleaning and drying the glass, place the glass back into its housing.
4. Turn the screw clockwise to replace and lock it in.

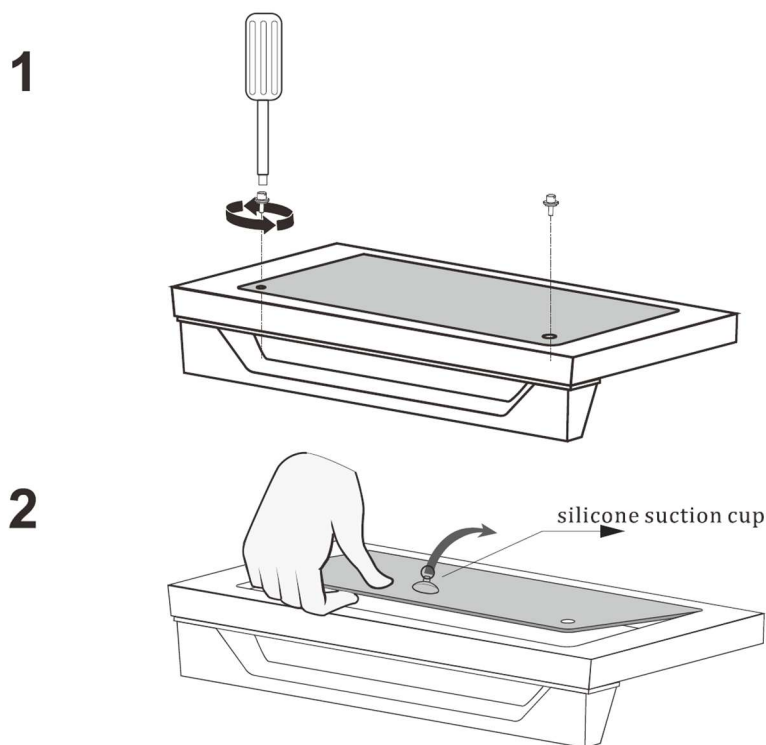

## ENVIRONMENTAL PROTECTION

Your appliance has been designed to run for many years. However, when you decide to replace it, remember to think about how you can contribute to protecting the environment.



This marking indicates that your appliance should not be disposed of with other household wastes throughout the UK or the EU. To prevent possible harm to the environment or human health from uncontrolled waste disposal, recycle this appliance responsibly to promote the sustainable reuse of material resources. Your appliance contains valuable materials which can be recovered or recycled. Leave it at a local civic waste collection point.

# STORAGE & TROUBLESHOOTING

---

Insert the crumb tray into the oven beneath the bottom heating elements before inserting all other accessories and close the door.

Store the oven in an upright position. **Do not** store anything on top of the oven.

## TROUBLESHOOTING

Problem	Possible Solution
The oven will not turn on	Make sure the oven is plugged in.
	Touch the POWER ON/ OFF icon to power on.
	Make sure the door is closed.
First time use: How do I condition the oven for ongoing use.	Upon first use, it is necessary to run the oven for 18 minutes at the highest temperature (230°C) in order to sterilize and remove any manufacturing odor. The appliance may even emit an odor or smoke due to the heaters protective film burning off.
Smelling a slight odor and smoke from appliance after using the appliance.	First time use – smells and smoke due to the production residue burning off the appliance and heating elements upon initial use. This is normal. The smell and smoke will fade away with use.
Steam is coming out from the top of the oven door.	You are cooking high moisture content foods. This is normal. The door is vented to release steam created from high moisture content food such as frozen bread.
Top heating elements are not working.	Above the top bars is a powerful fan directing air onto the top bars. The blown air dims the bars orange hot glow while circulating heat within the oven.  This is normal. No action needed. Top bars may seem to not be working as they are not glowing orange/red hot, but in fact, they are working. The top bars are hot, are dissipating heat, and operating as expected.

Foods are not completely cooked through.	Increase the cooking temperature or time.
Foods are over cooked or burned	Decrease the cooking temperature or time.
	Make sure food items are not too large and are not touching the heating elements.
Food cooked uneven	Preheat the oven manually by using the preheat function.
	Make sure food items are not too closely packed into a tray, rack, or other container.
White smoke or steam is coming out of the oven	The oven may produce some white smoke or steam during cooking. This is normal.
Dark smoke is coming out of the oven	Immediately press Power button, stop cooking, and unplug your oven. Food is burning. Wait for smoke to clear before opening the oven door.
Oil flow to crumb tray during cooking chicken	Put the baking pan in the low rack position to collect oil drippings.
A thermometer shows that the oven temperature is different from the oven setting	Commonly used thermometers usually have low sensitivity and take over 10 minutes to measure the correct temperature. This will not affect cooking.
Foods are not crispy after air frying	Ingredients with high moisture.
	Spraying or brushing a small amount of oil evenly on high moisture food can increase crispiness.
Fan still running after working	The temperature in the air fryer is still high after the oven has stopped cooking, so the fan will continue to turn for up to 4 minutes. This is normal for an air fryer appliance. The fan will turn off upon cooling.
Toaster not working.	Adjust the time up to 7 minutes and vary the toast color to your preference.
	Use the Time Range to control Toast function. For a golden-brown toast, consider default time 4 or 5 selection.
Display shows error code “E1”	There is an open circuit in the temperature monitor. Contact us at <a href="mailto:customerservice@bgepro.com">customerservice@bgepro.com</a>
Display shows error code “E2”	There is a short circuit in the temperature monitor. Contact us at <a href="mailto:customerservice@bgepro.com">customerservice@bgepro.com</a>

# WARRANTY

---

## REGISTER WARRANTY

Register your appliance online using the web link below within 14 days of purchase to validate your warranty.

Note the model number (543320) and serial number for your product before registering as it will be required in the registration process. The serial number is located at the back of the appliance.

Proof of purchase is required for a warranty claim.

[www.bgepro.com/warranty](http://www.bgepro.com/warranty)

# TERMS & CONDITIONS

---

BridgePro Management Ltd ("BPM").

**Limited Warranty:** This product is guaranteed for 12 months from the date of original purchase. This guarantee is valid in the UK only.

If any defect arises due to faulty materials or workmanship, the faulty products must be returned to the place of purchase. Refund or replacement is at the discretion of the retailer.

The following conditions apply:

- The product must be returned to the retailer with proof of purchase or a receipt.
- The product must be installed and used in accordance with the instructions contained in this instruction guide.
- It must be used only for domestic purposes.
- It does not cover wear and tear, damage, misuse or consumable parts.
- The product has limited liability for incidental or consequential loss or damage.

To validate your warranty, please visit [www.bgepro.com/support/warranty/](http://www.bgepro.com/support/warranty/) and register with us online. Warranty is only valid with proof of purchase or receipt.

This product warranty is available to consumers only.

You are a consumer if you purchased the product at retail for personal, family, or household use. Except as otherwise stated under applicable law, this warranty is not available to retailers or other commercial purchasers and owners.

This product warranty is void if the product is used for situations other than a single-family household use or subjected to any voltage and wave forms other than as specified in this instruction manual (e.g. 220V-50Hz).

**Transportation charges:** Transportation charges for products under this warranty, subject to repair or replacement, shall be borne by the purchaser.

**Conditions:** Service centers or retail stores do not have the right to alter, modify, or in any way change the terms and conditions of this warranty.

Warranty registration is not necessary but is encouraged to validate product warranty.

**About your warranty:** Most warranty repairs or replacements are handled routinely but sometimes requests for warranty services may not be appropriate, e.g. warranty services would NOT apply if the product damage occurred because of misuse, lack of routine maintenance, shipping, handling, 3rd party warehousing, or improper installation. Similarly, warranty is void if the serial number on the product has been removed or the product has been altered or modified.

**Normal wear:** This warranty does not cover normal wear of any parts or damage resulting from any of the following negligent use or misuse of the product:

- Improper voltage or current,
- Use contrary to the operation instructions,
- Deviation from the instructions regarding storage and transportation, or
- Repair or alteration by any 3rd party.

This warranty does not cover Acts of God such as fire, flood, hurricanes, and tornados.

BPM shall not be liable for any incidental or consequential damages by the breach of any express or implied warranty.

Except to the extent prohibited by applicable law any implied warranty of merchantability or fitness for the particular purpose is limited in duration of this warranty.

# NOTES

---